

Mobilkran/Mobile Crane

Grue mobile/Autogrù/Grúa móvil/Мобильный кран

LTM 1300-6.2



	300 t
	78 m
	94 m
	114 m

Inhaltsverzeichnis / Table of content

Tables des matières / Indice

Contenido / Оглавление

Technische Daten/Technical Data/Caractéristiques technique Dati tecnici/Datos técnicos/Технические данные

Maße/Dimensions/Encombrement Dimensioni/Dimensiones/Габариты крана	3
Mobilkran/Mobile Crane Grue mobile/Autogrù/Grúa móvil/Мобильный кран	4 – 5
Kraftstoffeinsparung und Geräuschreduktion/Fuel saving and noise reduction/Economie de carburant et réduction du bruit Risparmio di carburante e riduzione del rumore/Ahorro de combustible y reducción del ruido/Экономия топлива и снижение шума	6 – 7
Variables Auslegersystem/Variable boom systems/Systèmes de flèche variables/ Sistemi braccio variabili/Variable sistema de plumas/Вариабельные стреловые системы	8 – 10
VarioBase®/VarioBase®	11
Schnelles und effizientes Rüsten/Fast, efficient set-up process/Un montage d'équipement rapide et efficace/Allestimento rapido e semplice/ Equipamiento rápido y eficiente/Быстрый и эффективный монтаж	12 – 13
Auslegersysteme/Boom/jib combinations/Configurations de flèche Sistema braccio/Sistemas de pluma/Стреловые системы	14 – 16
Gewichte/Weights/Poids Geschwindigkeiten/Working speeds Pesi/Pesos/Нагрузки Vitesses/Velocità/Velocidades/Скорости	17
Ballast/Counterweight Contrepoids/Zavorra/Lastre/Противовес	18 – 19
T	20 – 26
TK	27 – 43
TNZK	44 – 60
TF	61 – 70
TN	71 – 83
Ausstattung/Equipment/Equipement Equipaggiamento/Equipamiento/Оборудование	84 – 89
Symbolerklärung/Description of symbols/Explication des symboles Legenda simboli/Descripción de los símbolos/Объяснение символов	90 – 91
Anmerkungen/Remarks/Remarques Note/Observaciones/Примечани	92

Maße / Dimensions

Encombrement / Dimensioni

Dimensiones / Габариты крана

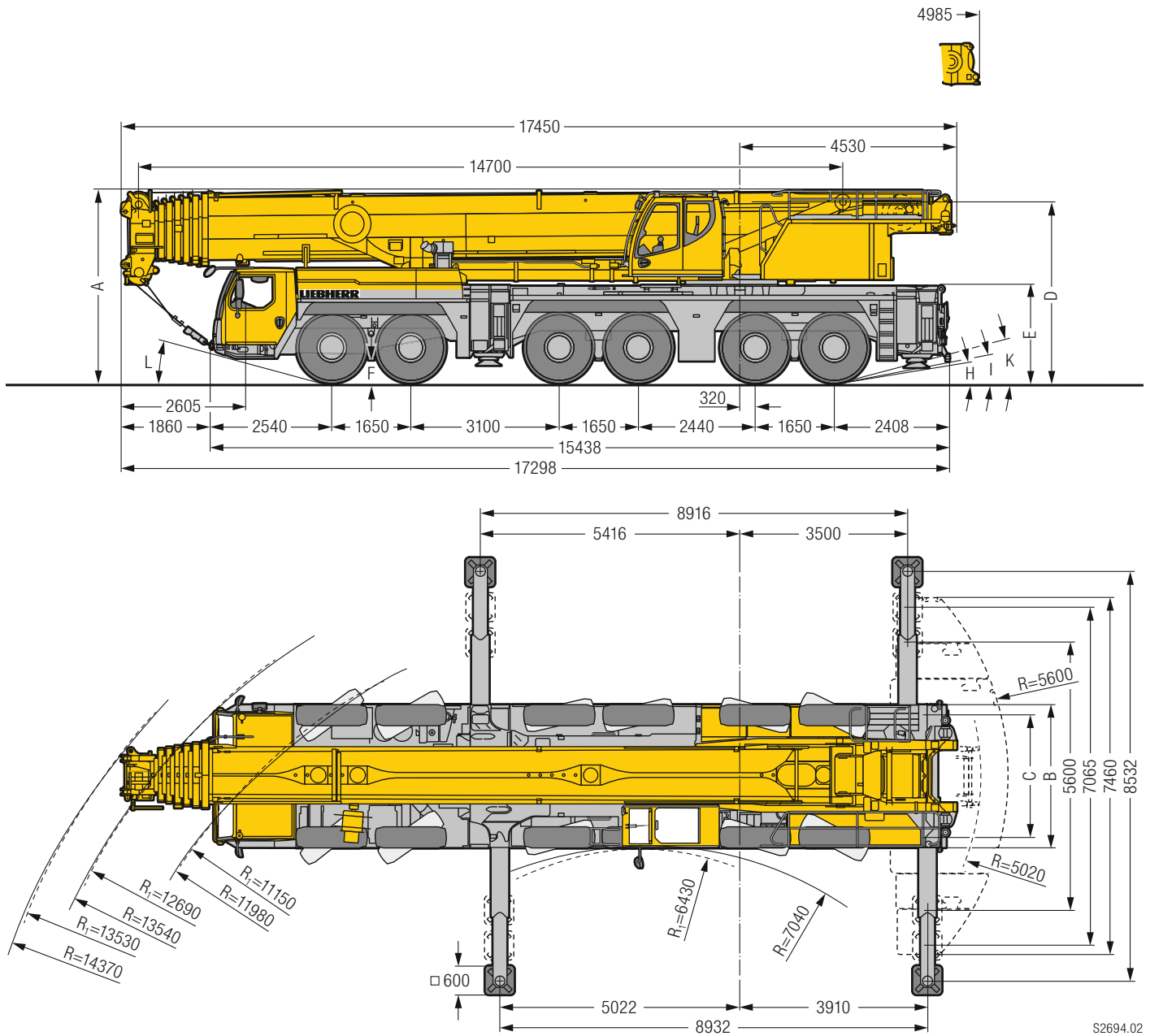

R₁ = Allradlenkung · All-wheel steering · Direction toutes roues · Tutti gli assi sterzanti · Dirección en todos los ejes · Поворот всеми колесами

Maße / Dimensions / Encombrement / Dimensioni / Dimensiones / Габариты крана mm

⊙	A	A 125 mm*	B	C	D	E	F	H	I	K	L
385/95 R 25 (14.00 R 25)	3950	3825	3000	2610	3685	1960	353	8°	9°	14°	12°
445/95 R 25 (16.00 R 25)	4000	3875	3000	2550	3735	2010	403	9°	10°	15°	14°
525/80 R 25 (20.5 R 25)	4000	3875	3100	2570	3735	2010	403	9°	10°	15°	14°

* abgesenkt · lowered · abaissé · abbassato · suspensión abajo · шасси осажено

Mobilkran/Mobile Crane

Grue mobile/Autogrù/Grúa móvil/Мобильный кран

LTM 1300-6.2

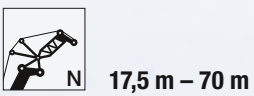
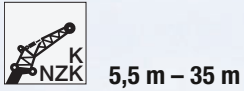

€COmode

€COdrive

TRAXON

Torque

